



TRAEGER[®]
WOOD PELLET GRILLS

OWNER'S MANUAL

BBQ070



RESIDENTIAL PELLET GRILL FOR OUTDOOR USE ONLY!

WARNING!
**DO NOT STORE OR USE COMBUSTABLE MATERIALS NEAR THIS
APPLIANCE!**

**USE ONLY TRAEGER BRAND HARDWOOD BBQ PELLETS IN THE
OPERATION OF THIS UNIT.**

INTRODUCTION

Congratulations on your purchase of this Traeger Wood Pellet Grill, Model BBQ070. With proper set-up, operation and maintenance, the Grill will provide you with delicious food and years of cooking enjoyment.

NOTE: NUMBERS FOLLOWING PART NAMES REFER TO THE COMPONENT DIAGRAM FOUND NEAR THE END OF THIS MANUAL.

When you un-box the Grill, remove all parts from the box and inside the Grill. Remove any remaining packaging material from inside the Grill as well. Make sure you have, and can identify all of the following parts:

<u>Qty</u>	<u>Item Description</u>	<u>Component Diagram Reference Number</u>
(1)	Grill -----	2
(1)	Hopper / Burner Assembly -----	31
(2)	Legs -----	122
(2)	Wheel Legs -----	127
(1)	Porcelain Grill -----	166
(1)	Grease Drain Pan -----	161
(1)	Heat Baffle -----	157
(1)	Smoke Stack -----	136
(1)	Chimney Cap Assembly -----	138
(1)	Chrome Door Handle -----	164
(1)	Grease Bucket -----	135
(1)	Hardware Kit -----	145

You will need to complete the assembly which includes:

- 1) Mounting the Legs (122) and Wheel Legs (127) to the Grill.
- 2) Attaching the Chrome Door Handle (164) to the Door (102).
- 3) Attaching the Smoke Stack (136) to the Grill.
- 4) Mounting the Chimney Cap Assembly (138).
- 5) Positioning the Heat Baffle (157) over the Firepot (72).
- 6) Positioning the Grease Drain Pan (161) over the Heat Baffle (157).
- 7) Positioning the Porcelain Grill (166) on the Grill Supports.
- 8) Hanging the Grease Bucket (135).

TOOLS ARE SUPPLIED FOR ASSEMBLY

- (2) Open end wrenches
- (1) Hex key (Allen Wrench)

Follow these step-by-step instructions and you'll be cookin' in no time!

SECTION ONE: ASSEMBLY INSTRUCTIONS

MOUNTING THE LEGS:

- 1) Carefully lay the Grill on its back on a non-abrasive surface. **Note:** The Hopper / Burner Assembly (31) will be mounted to the Grill, but is not shown in the diagram below for clarity.
- 2) Use the **Black** Bolts, Washers and Nuts (see Detail "A") supplied in the Hardware Kit (145) to install the Legs (122) on the left end of the Grill and the Wheel Legs (127) on the right end as shown in the diagram below. The Acorn Nuts (133) on the Wheel Legs (127) should go toward the center of the Grill. **Leave the Nuts loose** during this step.
- 3) Set the Grill upright to level and then tighten all Nuts.

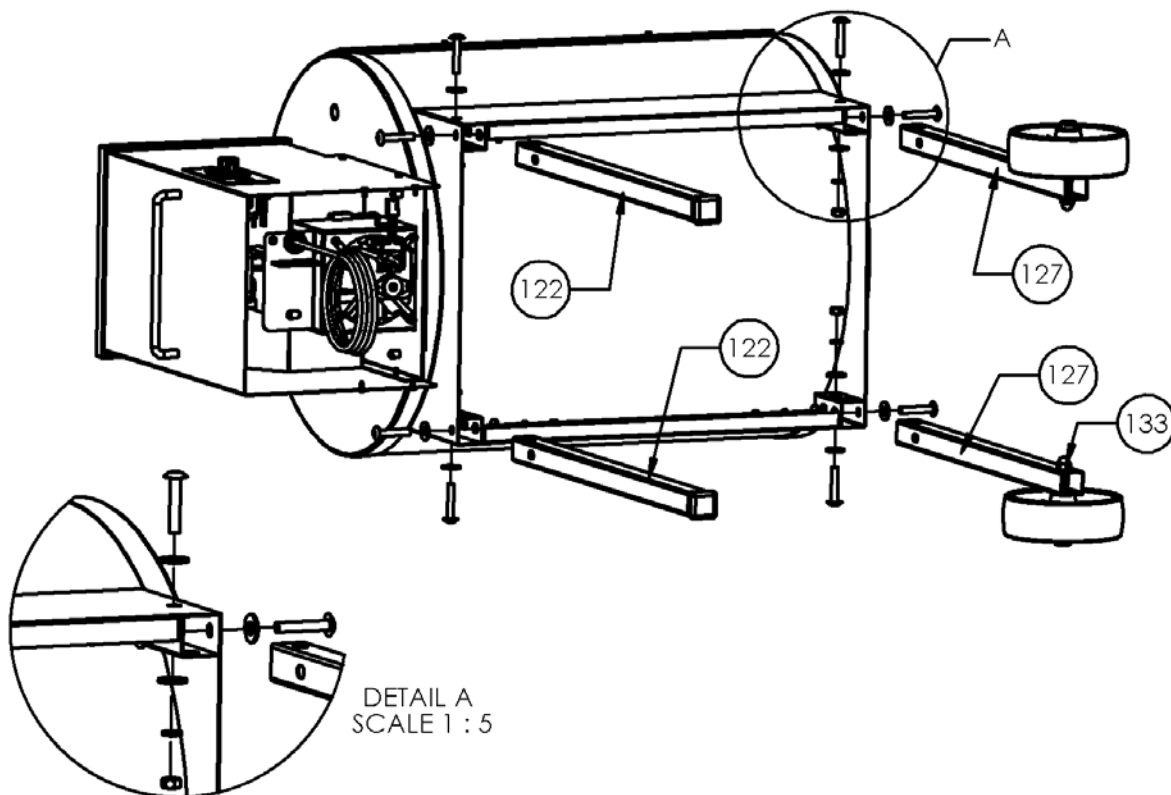

ATTACHING THE CHROME DOOR HANDLE:

- 1) Insert the threaded studs on the Chrome Door Handle (164) through the slots in the Door (102).
- 2) Place a Zinc Flat Washer, then a Zinc Lock Washer on each threaded stud. Secure with Hex Nuts using the Wrench supplied. **Do not** over tighten.

ATTACHING THE SMOKE STACK AND CHIMNEY CAP ASSEMBLY:

- 1) Align the holes in the Smoke Stack (136) with the holes in the Smoke Stack Gasket (144), which fits between right end of the Grill and the Smoke Stack (136).
- 2) Place Zinc Flat Washers on two of the 1/2" long Hex Head Bolts and insert the Bolts through the holes in the Smoke Stack (136) and the Smoke Stack Gasket (144).
- 3) Align the Bolts with the corresponding holes in the Grill. Place a Zinc Flat Washer on each Bolt inside the Grill and secure with Hex Nuts using the Wrench supplied.
- 4) Screw the Chimney Cap Assembly (138) into the Bracket in the top of the Smoke Stack. **Hand tighten.**

NOTE: If at this point you are ready to start your Grill, refer to the INITIAL FIRING INSTRUCTIONS in SECTION TWO of this manual or on a separate sheet in the PELLET HOPPER, before proceeding with further assembly.

POSITIONING THE HEAT BAFFLE:

Position The Heat Baffle (157) directly over the Firepot (72) on the locating brackets located on the inside walls of the Grill. The notched legs of the Heat Baffle (157) should be facing downward to fit onto the locating brackets.

POSITIONING THE GREASE DRAIN PAN:

RECOMMENDATION for ease of clean-up: Line the Grease Drain Pan (161) with heavy-duty aluminum foil. Be sure the edges and ends of the foil are tight against the bottom of the Grease Drain Pan (161).

Position the Grease Drain Pan (161) so that the Short Lip end hooks over the Grease Drain Pan Support on the left side of the Grill. The Long Lip end should rest in the V-Shaped Grease Drain (23) located inside the Grill on the right.

POSITIONING THE PORCELAIN GRILL:

Position the Porcelain Grill (166) on the Grill Supports that run the length of the cooking area.

HANGING THE GREASE BUCKET:

Locate the Grease Drain Tube, extending from the Grill below the Smoke Stack (136) on the right end. Hang the Grease Bucket (135) on the Bucket Hook.

SECTION TWO: INITIAL FIRING INSTRUCTIONS

(To be used on initial firing or anytime the Grill runs out of Pellets)

In order to ensure proper operation of the Grill, you must first allow the Auger Tube to be “charged” with Pellets.

- 1) Open the Door/Lid and remove the Porcelain Grill, Grease Drain Pan and Heat Baffle from inside the Grill.
- 2) Make sure the Switch/Dial is in the OFF position. Plug the Power Cord into an appropriate, grounded electrical outlet.
- 3) Open the Pellet Hopper Lid and locate the Auger. Make sure there are no foreign objects in the Auger. Turn the Switch/Dial ON and look into the Pellet Hopper to confirm the Auger is turning. At the same time, place your fingers over the Firepot and feel the air movement from the Draft Inducer Fan. Look to see if the Hot Rod is getting hot. **DO NOT TOUCH IT!** Turn the Switch/Dial OFF.
- 4) Fill the Pellet Hopper with TRAEGER BBQ PELLETS. **WARNING! USE ONLY TRAEGER BRAND BBQ PELLETS, which are specifically made to work in our Grills. NEVER use heating fuel pellets in the Grill due to potential hazardous contaminants that may be present.** Turn the Switch/Dial ON, set the Temperature Dial to HIGH. Note: During the initial charging of the Auger, it will take time for the Pellets to travel from the Pellet Hopper to the Firepot. When the Pellets begin to fall into the Firepot, turn the Switch/Dial OFF.
- 5) Turn the Switch/Dial ON, set the Temperature Dial to SMOKE. Let the Pellets come to full flame. Once you see flames come out of the Firepot, turn the Switch/Dial OFF, and let the Grill cool down.
RECOMMENDATION for ease of clean-up: Line the Grease Drain Pan with heavy-duty aluminum foil. Be sure the edges and ends of the foil are tight against the bottom of the Grease Drain Pan. Position the Heat Baffle, the foil lined Grease Drain Pan and Porcelain Grill in their proper locations.
- 6) With the Door/Lid open, turn the Switch/Dial ON and set the Temperature Dial to SMOKE. In approximately 2 minutes you will notice whitish-gray smoke coming out of the Grill as the Pellets ignite. After assuring the Pellets have ignited, close the Door/Lid and set the Temperature Dial to any cooking setting desired.
- 7) **Note: Before cooking the first batch of food in your new Grill, you will need to season the Grill. Turn the Temperature Dial to HIGH and run for 45 minutes at this setting with the Door/Lid closed. This must be done before cooking any food on the Grill.**
- 8) The Grill should be allowed to pre-heat for approximately 10 minutes with the Door/Lid closed before placing food in the Grill.

**ALWAYS START THE GRILL ON SMOKE SETTING
WITH THE DOOR/LID OPEN**

**Once the Pellets are ignited, close the Door/Lid and
set the Temperature Dial to any cooking temperature desired.**

**NOTE: When operating this Grill, maintain a minimum
clearance of 10 inches from Grill to combustibles**

SECTION THREE: SUBSEQUENT START-UP

With the Door open, turn the Switch/Dial ON and Temperature Dial to SMOKE. In approximately 2 minutes you will notice whitish-gray smoke coming out of the Grill as the Pellets ignite. After assuring the Pellets have ignited, close the Door and set the Temperature Dial to any cooking setting desired.

If the Grill fails to light or if the fire in the Firepot goes out while cooking or smoking, follow these steps:

- 1) Turn the Switch/Dial to OFF. Open the Door and remove all food, Porcelain Grill, Grease Drain Pan and Heat Baffle.
- 2) **IMPORTANT: Remove all unburned Pellets and ash from inside and around the Firepot.**
- 3) **Before replacing the Heat Baffle, Grease Drain Pan and Porcelain Grill,** restart the Grill and confirm that the ignition cycle is working. (The Hot Rod should begin to turn red and Pellets should fall into the Firepot from the Auger Tube.)
- 4) If this procedure is not successful, see **SECTION SIX: FREQUENTLY ASKED QUESTIONS** for troubleshooting tips or contact Traeger Technical Support (**SECTION SEVEN**) to help diagnose the problem before proceeding to the **MANUAL LIGHTING INSTRUCTIONS** below.

MANUAL LIGHTING INSTRUCTIONS:

If the **Hot Rod** only is not operating, the Grill can still be used to cook and smoke using the **MANUAL LIGHTING PROCEDURE** below:

- 1) Making sure the Switch/Dial is set to OFF and the Hot Rod connector (Purple / White wire pair) is **disconnected**, plug the Power Cord into an appropriate, grounded electrical outlet.
- 2) Open the Pellet Hopper and fill with TRAEGER BBQ PELLETS. **WARNING! USE ONLY TRAEGER BRAND BBQ PELLETS, which are specifically made to work in our Grills. NEVER use heating fuel pellets in the Grill.**
- 3) Remove the Porcelain Grill, Grease Drain Pan and Heat Baffle to expose the Firepot in the bottom of the Grill.
- 4) Pour 1/2 cup of TRAEGER BBQ PELLETS into the Firepot.
- 5) Squirt 2 tablespoons of Alcohol Gel fire lighter into the Firepot on top of the Pellets.
- 6) Light the Alcohol Gel with a fireplace match or a long-reach butane lighter. **WARNING! NEVER SQUIRT ALCOHOL GEL INTO A BURNING FIRE OR A HOT FIREPOT. THE ALCOHOL GEL BOTTLE COULD EXPLODE AND CAUSE SERIOUS INJURY.**
- 7) Let the Alcohol Gel and Pellets burn for approximately 4 minutes.
- 8) After assuring the Pellets have ignited, install the Heat Baffle, Grease Drain Pan and Porcelain Grill back in place.
- 9) Turn the Switch/Dial ON and the Temperature Dial to any setting desired. With the Door closed, let the Grill pre-heat for approximately 10 minutes before placing food in the Grill.

Control Shutdown cycle

The control for this barbecue comes with an automatic shut down cycle. When finished cooking on your barbecue set the Temperature/Dial Knob to the Shutdown Cycle position, this will leave the Draft Induction Fan running for ten minutes to burn any excess pellets in the fire pot. After the fan runs for ten minutes the controller will power off and the fan and it will stop running. **CAUTION!** The main power switch will shut the power off to the controller and the Temperature/Dial Knob switch will cut off power to the grill components only. When servicing the controller or any parts ensure that the power supply is disconnected to avoid a shock hazard.

SECTION FOUR: OPERATING TIPS

- 1) The Temperature Dial can be changed at any time to increase or decrease the cooking temperature of the Grill. The HIGH/HIGHER Temperature settings are for Grilling. The MED/MID RANGE Temperature settings are for Slow Cooking. The SMOKE setting is for Smoking and adding Smoke Flavor to foods being cooked. The SMOKE setting can also be used to “hold” foods at approximately 180 to 200 degrees F.
- 2) Your TRAEGER PELLET GRILL should never be moved while it is hot. If you are transporting your Grill in a vehicle after cooking on it, make sure the fire is completely out and the Grill is COLD before placing it in any vehicle. NEVER put water into the Firepot. It will jam the Auger.
- 3) The TRAEGER PELLET GRILL is designed to operate with the Door CLOSED. Cooking with the Door open greatly lengthens your cooking time.
- 4) NEVER add Pellets by hand to a hot Firepot. This is dangerous and you may be seriously burned. If you run out of Pellets and lose your fire while cooking, let the Grill completely cool and start again with the **INITIAL FIRING INSTRUCTIONS**.
- 5) Make sure the Heat Baffle is properly seated on its locating brackets. The long lips of the Heat Baffle should be pointing down over the Firepot. If not seated properly, direct heat and flame could come up out of the Firepot and cause a grease fire in the Grill.
- 6) When estimating cooking times, the outside temperature will be an important factor. If it is hot outside, it will take less time for food to cook. If it is cold, wet or windy, it will take longer.
- 7) Grease fires are caused by not properly maintaining the Grill by failing to clean your Grease Drain Pan, V-shaped Grease Drain and Grease Drain Tube on a consistent basis. In the unlikely event of a grease fire while cooking, **TURN THE SWITCH/DIAL OFF and KEEP THE DOOR CLOSED** until the fire is completely out. Never keep the Door open during a grease fire. If it does not go out, lightly sprinkle baking soda on the fire. **Be careful not to burn yourself**. If this does not work, then carefully remove the food from the Grill and keep the Door closed until the fire is completely out. **Again, be careful not to burn yourself**. When the Grill is completely cool, remove the Porcelain Grill and replace the foil on the Grease Drain Pan. Clean any grease accumulation from the V-shaped Grease Drain and the Grease Drain Tube. Replace the Grease Drain Pan and the Porcelain Grill in their proper positions, restart the Grill and resume cooking.

SECTION FIVE: MAINTAINING YOUR NEW GRILL

- 1) Change the aluminum foil on the Grease Drain Pan frequently. Periodically, clean the grease out of the V-shaped Grease Drain and Grease Drain Tube and off of the interior surfaces of the Grill. Empty the Grease Bucket occasionally and line with aluminum foil for easy clean-up. It is easier to clean off accumulated grease when the Grill is warm. **BE CAREFUL NOT TO BURN YOURSELF.** If too much grease is allowed to build up on the Grease Drain Pan and in the V-shaped Grease Drain, or is allowed to plug the Grease Drain Tube, a grease fire could result. We recommend cleaning these locations regularly.
- 2) Outside surfaces: DO NOT use oven cleaner, abrasive cleansers or abrasive cleaning pads on the outside Grill surfaces. Use warm soapy water to cut the grease.
- 3) If the Grill is stored outside during the rainy season, care should be taken to ensure that water does not get into the Pellet Hopper. Wood pellets, when wet, expand greatly and will jam your Auger. **A TRAEGER GRILL COVER to protect the Grill is highly recommended! Covers are available from your Traeger Dealer, or log on to our Web Site – www.traegergrills.com.**
- 4) Depending on use, periodically remove the Porcelain Grill, Grease Drain Pan and Heat Baffle to clean the ash from in and around the Firepot. A shop-vac is handy for this chore. Make sure the Grill is COLD before starting this procedure.
- 5) We recommend keeping a long-handled cleaning brush near the Grill. After removing your food, give the Porcelain Grill a quick brushing. It takes only a minute and it will be ready the next time you want to use the Grill. **Be careful not to burn yourself.**

SECTION SIX: FREQUENTLY ASKED QUESTIONS

WHY WON'T MY GRILL IGNITE?

- 1) Verify power at the electrical outlet.
 - a) If Power Cord is connected to a GFI (Ground Fault Interrupter), check and reset if necessary.
 - b) Initiate startup.
Still no ignition – Proceed to step 2.
- 2) Disconnect Power Cord from electrical outlet.
 - a) Remove the Control and check the fuse on back. Replace the fuse if blown.
Reinstall the Control!
 - b) Unplug Hot Rod connector (Purple/White wire pair), plug Power Cord into an appropriate, grounded electrical outlet and turn the Switch/Dial ON. **NOTE: At this point the Grill will not ignite.**
 - c) Check the Draft Inducer Fan and the Auger Drive Motor for operation. If both are operating -- the Hot Rod needs to be replaced. If one or both are not operating, contact Traeger Technical Support (**SECTION SEVEN**) for additional

troubleshooting help. Contact your Traeger Dealer or the Traeger Parts Department (**SECTION SEVEN**) to place an order.

- 3) If the problem is identified to be a failed Hot Rod, the Grill can still be used to cook and smoke by following the **MANUAL LIGHTING INSTRUCTIONS** in **SECTION THREE** of this OWNER'S MANUAL.

WHY ARE NO PELLETS BEING DELIVERED INTO THE FIREPOT?

- 1) Verify that there are Pellets in the Pellet Hopper. If this is the **INITIAL FIRING** or the Grill has run out of Pellets, allow sufficient time for the Pellets to travel from the Pellet Hopper to the Firepot (can take up to 7 minutes).
- 2) Initiate startup. See **INITIAL FIRING INSTRUCTIONS** in **SECTION TWO** of this OWNER'S MANUAL.

Still no Pellets in the Firepot – Proceed to step 3.

- 3) Disconnect Power Cord from electrical outlet.
 - a) Unplug the Auger Drive Motor (Red/White wire pair connector) and the Draft Inducer Fan (Orange/White wire pair connector).
 - b) Reconnect the Draft Inducer Fan to the Red/White wire pair and the Auger Drive Motor to the Orange/White pair.
 - c) Plug Power Cord into an appropriate, grounded electrical outlet and turn the Switch/Dial ON.
 - d) If the Auger Drive Motor **is** operating (check the small fan blade on the back of the motor), the problem is in the Three Speed or Digital Control, which will need to be replaced. Contact your Traeger Dealer or the Traeger Parts Department (**SECTION SEVEN**) to place an order.

- 4) If the Auger Drive Motor **is not** operating but the Draft Inducer Fan **is** operating, the problem is in the Auger system, which will need to be checked.
 - a) With the Switch/Dial OFF, locate the small fan blade on the back of the Auger Drive Motor.
 - b) While watching the fan blade, turn the Switch/Dial to ON. If the fan blade **does not** turn, turn the Switch/Dial to OFF. This indicates a defective Auger Drive Motor and it will need to be replaced. Contact your Traeger Dealer or the Traeger Parts Department (**SECTION SEVEN**) to place an order.
 - c) If the fan blade turns a bit and then stops, continue watching and turn the Switch/Dial to OFF. If the fan blade UNWINDS slightly, this indicates a jam in the Auger system which will need to be cleared.
 - d) Disconnect Power Cord from electrical outlet and remove Pellets from the Pellet Hopper. Check for foreign objects and wet/decomposed Pellets, both of which can cause a jam in the Auger system. The Auger will need to be removed to clear a jam in the Auger system. See "HOW DO I REMOVE THE AUGER IF IT JAMS?" section below.

HOW DO I REMOVE THE AUGER IF IT JAMS?

- 1) Remove any covers necessary to access the Auger Drive Motor.

- 2) Remove the screw connecting the Auger Drive Motor shaft to the Auger shaft and the screw retaining the Auger Bushing into the Auger Tube.
- 3) With a small pipe wrench or locking pliers on the Auger shaft, turn the Auger counter clockwise. It will turn hard until it breaks free, then the Auger will turn freely.
- 4) Remove the Auger and clean all Pellets, ash or foreign objects from the Auger, Auger Tube and Firepot. A shop-vac is ideal for this task.
- 5) Sand the outside surfaces of the auger with medium grit sandpaper. Check the inside of the Auger Tube and sand it if needed. Vacuum sanding grit out of the Auger Tube and Firepot when finished.
- 6) Reinstall the Auger Bushing and the Auger into the Auger Tube, making sure that the Auger rotates freely.
- 7) Re-attach the Auger shaft to the Auger Drive Motor shaft.

WHY DOES MY GRILL FIRE GO OUT ON “SMOKE” SETTING?

Excess ash in the Firepot may be the problem.

- 1) Open the Door and remove the Porcelain Grill, Grease Drain Pan and Heat Baffle from inside the Grill.
- 2) **IMPORTANT: Remove all unburned Pellets and ash from inside and around the Firepot.** A shop-vac is ideal for this task **CAUTION! ASSURE THAT THE GRILL IS COLD TO AVOID A FIRE FROM HOT ASH.**
- 3) Replace the Heat Baffle, Grease Drain Pan and the Porcelain Grill and initiate start-up procedure.
- 4) If this didn't remedy the problem, contact Traeger Technical Support (**SECTION SEVEN**) for additional troubleshooting help.

WITH THE TRAEGER DIGITAL CONTROL, WHAT DIAL SETTING IS RECOMMENDED FOR STARTING THE GRILL?

The auto-start procedure is the same for all Grill Controls. With the Door open, turn the Switch/Dial ON and Temperature Dial to SMOKE. In approximately 2 minutes you will notice whitish-gray smoke coming out of the Grill as the Pellets ignite. After assuring the Pellets have ignited, close the Door and set the Temperature Dial to any cooking setting desired.

HOW DO I PROTECT MY PAINT FINISH?

- 1) Use a protective Cover on the Grill and touch-up paint to repair any scratches. **A TRAEGER GRILL COVER to protect the Grill is highly recommended! Covers and touch-up paint are available from your Traeger Dealer, or log on to our Web Site – www.traegergrills.com.**
- 2) Every 90 days, use a high quality car wax on the outside surfaces of the Grill. **ONLY APPLY WAX TO A COLD GRILL.**

WHERE CAN I GET A NEW PART FOR MY GRILL?

Check with your Traeger Dealer. They may have the part in stock or can order the part for you. Or you can contact the Traeger Parts Department (**SECTION SEVEN**) to place an order. In either case, please provide your name, phone number, address, Model and Serial Number of the Grill (located on a label inside the Hopper Lid), along with the part identification.



TRAEGER®

WOOD PELLET GRILLS

SECTION SEVEN: TRAEGER SUPPORT

Parts are identified in the front of this manual on the COMPONENT DIAGRAM PAGE. To order parts: Call, E-mail or write to your Traeger Dealer or Traeger Pellet Grills. Please provide your name, phone number, address, Model and Serial Number of the Grill (located on a label inside the Hopper Lid), along with the part identification.

TRAEGER PELLET GRILLS, LLC.
9445 SW Ridder Road #310
Wilsonville, OR 97070

TRAEGER TECHNICAL SUPPORT
Available 24/7

TRAEGER PARTS DEPARTMENT
Available Weekdays 8AM to 4:30PM
Pacific Time

TRAEGER SALES/ORDER DESK
Available Weekdays 8AM to 5PM
Pacific Time

TOLL-FREE TELEPHONE: 1-800-872-3437

E-mail: service@traegergrills.com
Website: www.traegergrills.com

BBQ070 COMPONENT DIAGRAM

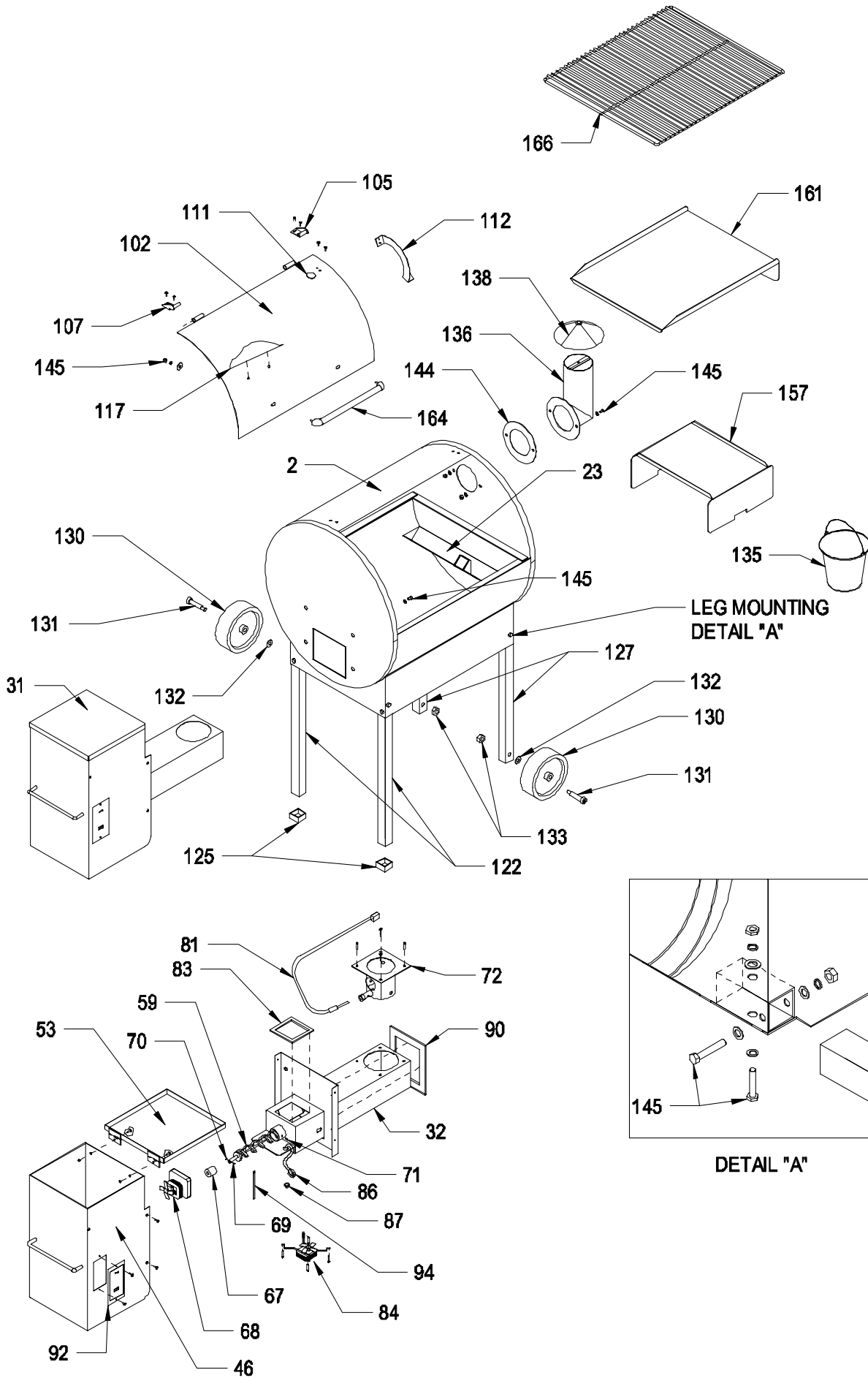

BBQ070 WIRING DIAGRAM

